

DESIGN NOTES

High Efficiency 100mA Synchronous Buck Converter with Wide Input Range from 4V to 150V

Design Note 532

Charlie Zhao

Introduction

The wide 4V to 150V input range of the **LTC[®]3639** step-down DC/DC converter allows automotive, avionics and distributed power systems to:

- Cover extensive transient requirements
- Enable multiple wide-ranging input power sources, such as a high voltage DC bus with a low voltage battery backup
- Create a universal power supply to cover a variety of input sources, thereby reducing inventory and the cost of design and manufacture

The LTC3639 converts at high efficiency with internal high side and low side power MOSFETs. It can support up to 100mA output current and features a programmable peak current limit. Its output voltage range is also broad, from 0.8V to the input voltage. The integrated high side MOSFET can work at 100% duty cycle for low dropout operation. High efficiency is achieved across the wide input and output voltage ranges. Burst Mode[®] operation and low quiescent current are also features of this synchronous buck converter. The loop is inherently stable without compensation because of the hysteretic nature of the control architecture, resulting in a simple easy to use application circuit.

4V to 150V Input to 3.3V Output, 100mA Buck Converter

Figure 1 shows a 3.3V output, 100mA maximum load current synchronous buck converter, with wide input range from 4V to 150V. The LTC3639 has three programmable fixed output voltages 1.8V, 3.3V and 5V. These fixed outputs use an internal feedback resistor divider and can be simply selected with the V_{PRG1} and V_{PRG2} pins. For 3.3V output, just connect V_{PRG1} to ground and tie V_{PRG2} to the SS pin. The V_{FB} pin is directly connected to the output without using an external resistor divider. Efficiency curves with different input voltages are shown in Figure 2.

36V to 72V Input to 24V Output, 100mA Buck Converter

The LTC3639 has a very wide output voltage range, from 0.8V to the input voltage. Besides the selectable three fixed output voltages, an adjustable output voltage can be set with an external resistor divider. Figure 3 shows an application example of a 24V output, 100mA synchronous step-down converter. The input voltage range is controlled from 36V to 72V, with the

LT, LT, LTC, LTM, Linear Technology, the Linear logo and Burst Mode are registered trademarks of Linear Technology Corporation. All other trademarks are the property of their respective owners.

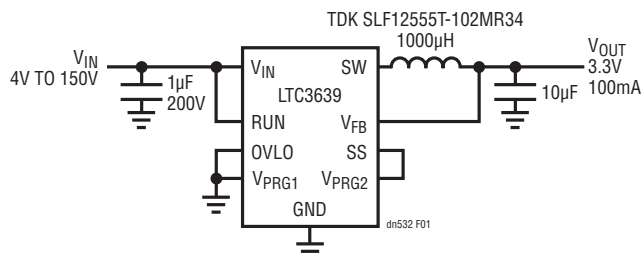

Figure 1. 4V to 150V Input to 3.3V Output, 100mA Synchronous Buck Converter

Efficiency vs Load Current, $V_{OUT} = 3.3V$

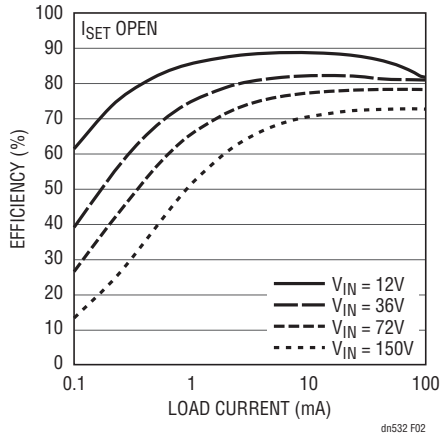

Figure 2. Efficiency Curves of the Converter in Figure 1

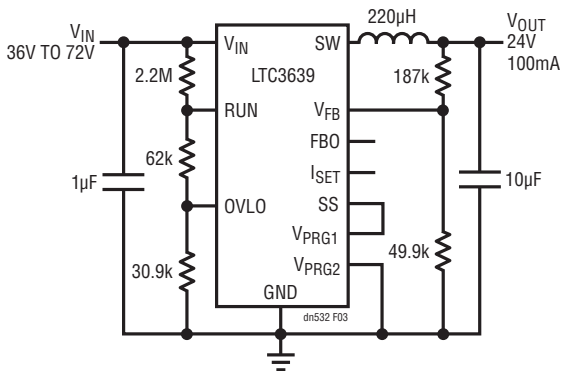

Figure 3. 36V to 72V Input to 24V, 100mA Buck Converter with Input Overvoltage and Undervoltage Lockout

overvoltage lockout and undervoltage lockout features of the LTC3639. The input operating range is easily set with a resistor divider from the V_{IN} to the RUN pin and the OVLO pin, as shown in Figure 3.

Negative Output Voltage Applications

An additional useful application for the LTC3639 is to generate a negative voltage from a positive one. The

part's wide voltage range makes even large negative output voltages realizable. Figure 4 shows the implementation of a $-15V$ output regulator from a 4V to 135V input. Since the output is connected to the ground pin, the maximum input voltage is limited to the sum of 150V and the $-15V$ regulated output, or 135V. The maximum output current for the LTC3639 in this positive-to-negative configuration is about $100mA \cdot V_{IN}/(V_{IN} + |V_{OUT}|)$.

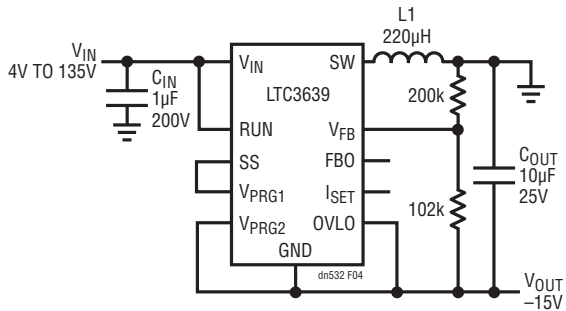

Figure 4. 4V to 135V Input to $-15V$ Output Positive-to-Negative Regulator

Conclusion

The LTC3639 has a very wide input voltage range, very wide output voltage range, integrated power MOSFETs, low quiescent current (1.4µA in shutdown and 12µA in sleep mode) and high efficiency across a wide load current range. Rich features include programmable or adjustable output, adjustable current limit, no compensation required, internal or external soft-start, programmable overvoltage and undervoltage lockout. Additionally, the thermally enhanced small MSE package and simple application circuit offer a high performance, small and cost effective DC/DC converter solution for automotive systems, avionics, distributed power systems, medical devices and industrial control supplies.

Data Sheet Download

www.linear.com/LTC3639

For applications help,
call (408) 432-1900, Ext. 3258